



POLYMER 80
MACHINING
INSTRUCTIONS



©2013 James Madison Tactical, LLC

YOUR KIT INCLUDES:

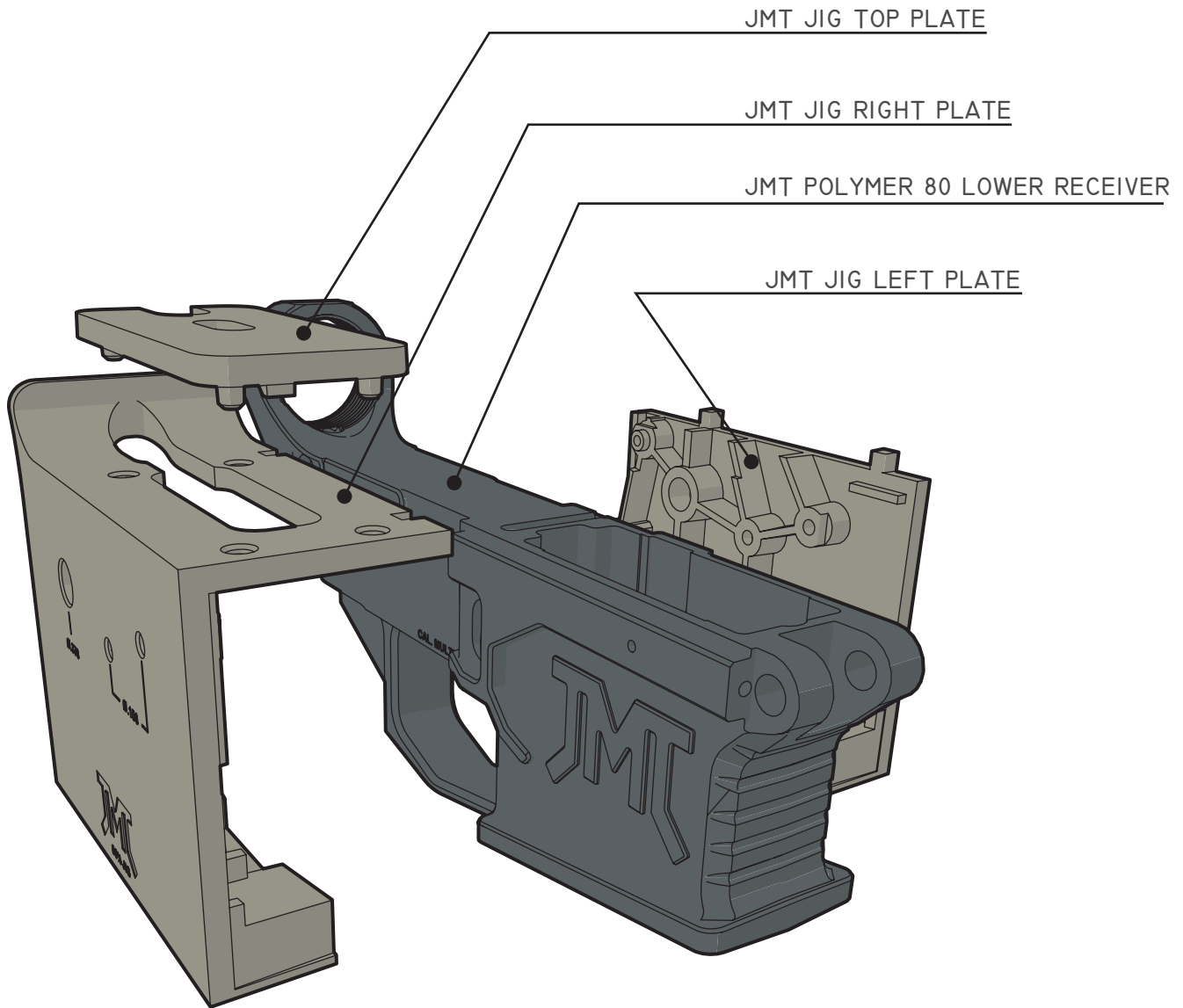

TOOLS REQUIRED:



3/8" DIA. (.375") DRILL BIT



5/16" DIA. (.313") DRILL BIT OR CUTTER



5/32" DIA. (.156") DRILL BIT



5/16" DIA. 5/16" SHANK 4FL HSS END MILL



RAZOR, CRAFT KNIFE, OR DEBURRING TOOL

DRILL PRESS, MILL, MACHINE VISE (NOT SHOWN)



IMPORTANT NOTES:

READ THE INSTRUCTIONS START TO FINISH BEFORE BEGINNING.

ALWAYS USE EYE PROTECTION AND EXERCISE CAUTION WHEN OPERATING MACHINERY.

USING NEW, SHARP TOOLS IS HIGHLY RECOMMENDED.

WE RECOMMEND **600 TO 800 RPM** WHEN CUTTING.

CHECK OUT THE MACHINING VIDEOS ON OUR WEBSITE WWW.JAMESMADISONTACTICAL.COM AND YOUTUBE CHANNEL.

IF YOU ARE NEW TO OR UNFAMILIAR WITH MACHINING, WE RECOMMEND RESEARCHING THE BASICS BEFORE ATTEMPTING. THE INTERNET IS A GREAT RESOURCE FOR INFORMATION ON MACHINING TECHNIQUES AND BEST PRACTICES, THERE ARE NUMEROUS MESSAGE BOARDS AND WEBSITES ON THE INTERNET DEVOTED TO THE TOPIC.

HAVE ALL REQUIRED TOOLS.

MAKE SURE YOUR MACHINING TABLE AND VISE ARE PROPERLY LEVELED. THIS WILL ENSURE ALL HOLES AND POCKETS ARE ACCURATE AND ALIGNED.

DRILL HOLES WITH THE JMT JIG RIGHT PLATE (SIDE WITH THE JMT LOGO) FACING UP SO THE HOLE DIAMETERS CAN BE READ.

DO NOT DRY-FIRE! DRY-FIRING WITHOUT A FULLY ASSEMBLED LOWER AND UPPER WILL DAMAGE THE LOWER RECEIVER.

DRILLING:

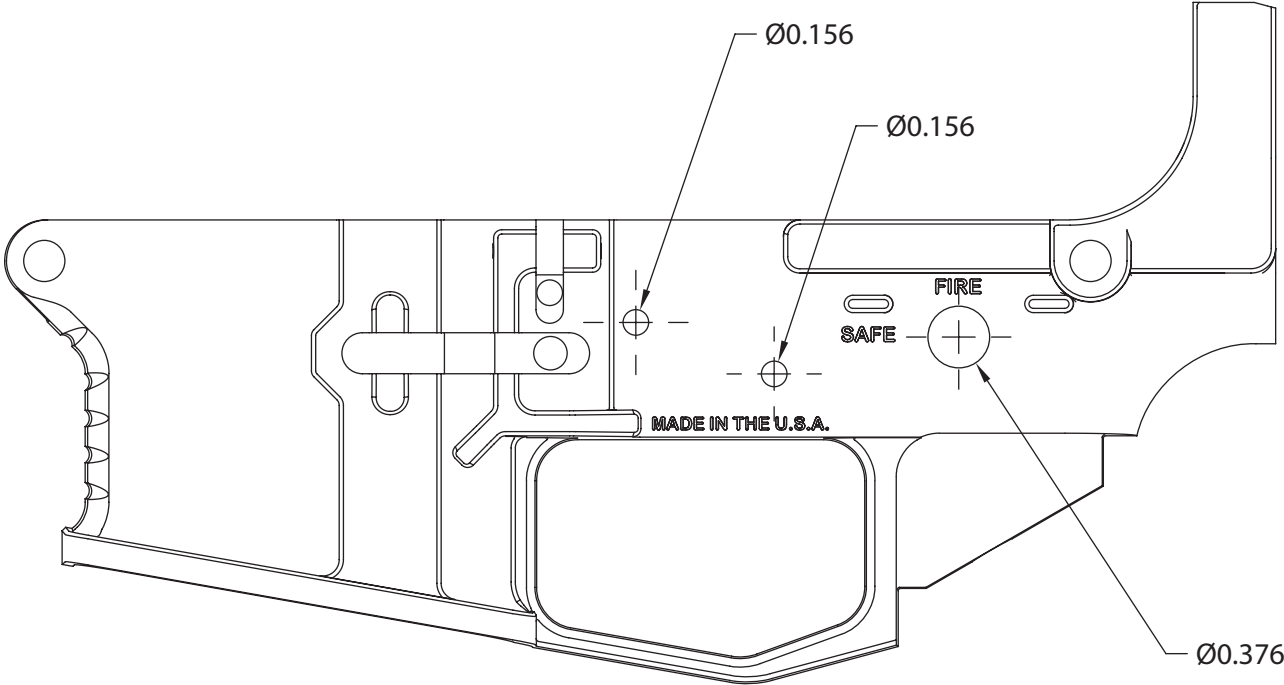
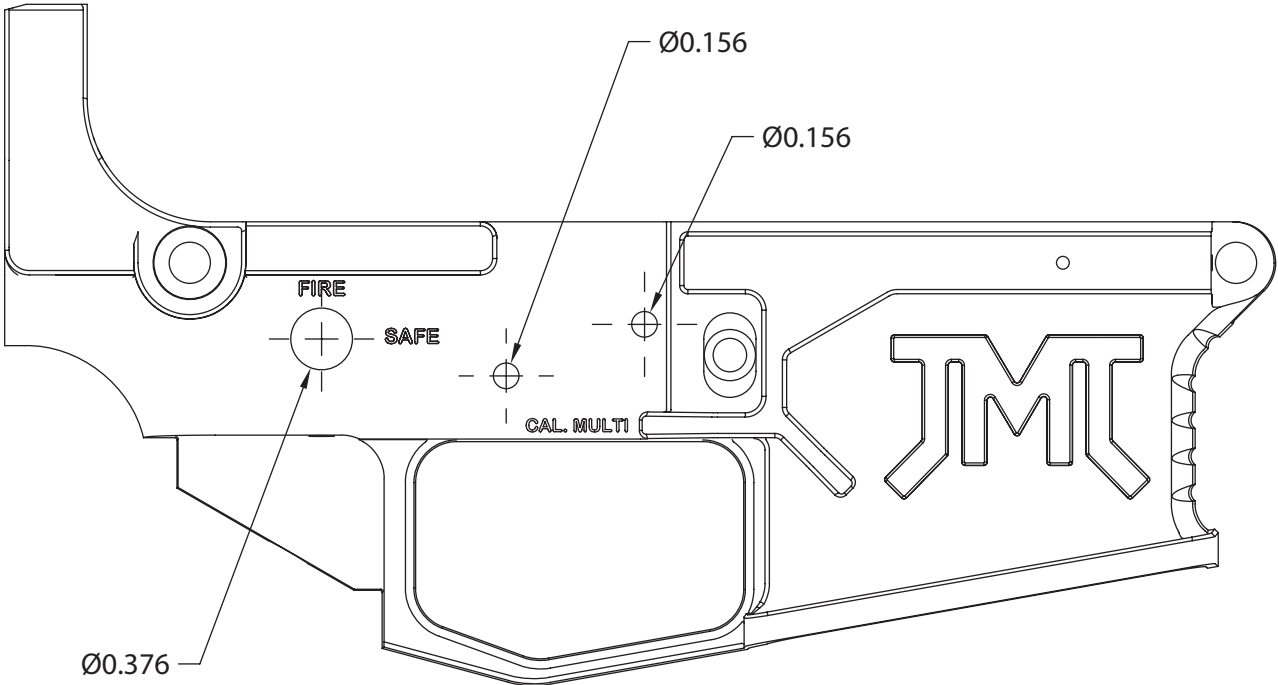

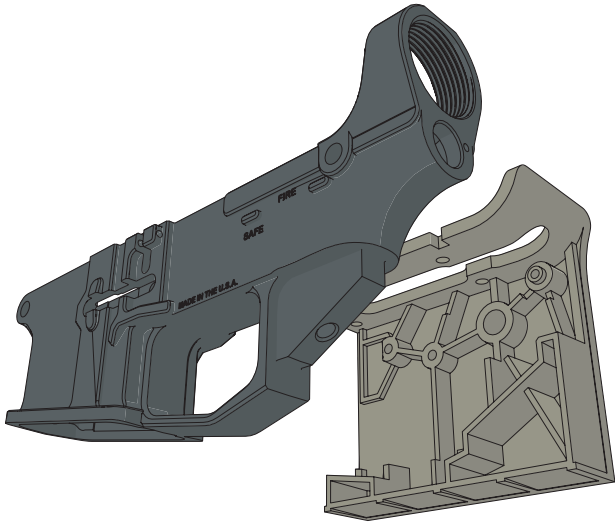

SNAP THE LOWER RECEIVER IN TO THE JIG RIGHT PLATE.

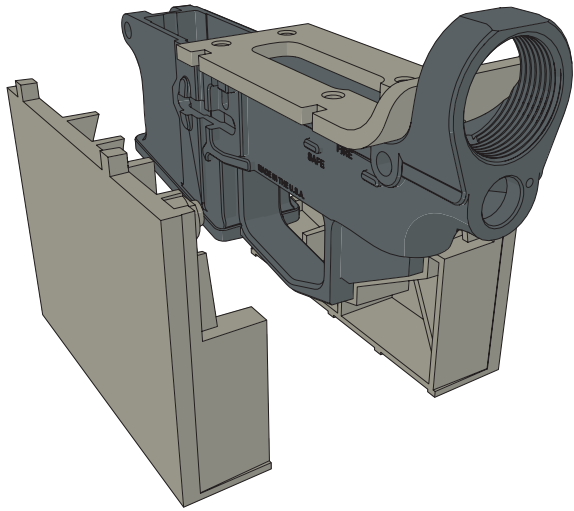

SNAP THE JIG LEFT PLATE ON TO THE LOWER RECEIVER AND JIG RIGHT PLATE AS SHOWN.

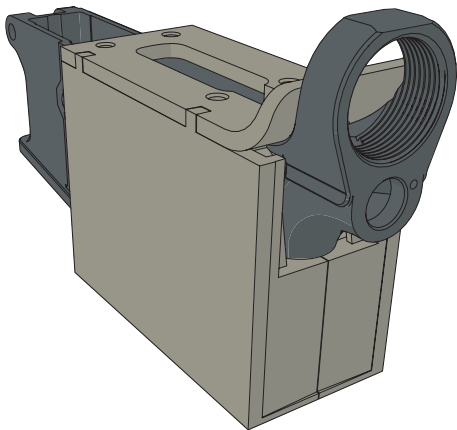

LEAVE THE JIG TOP PLATE OFF FOR THE DRILLING OPERATION.

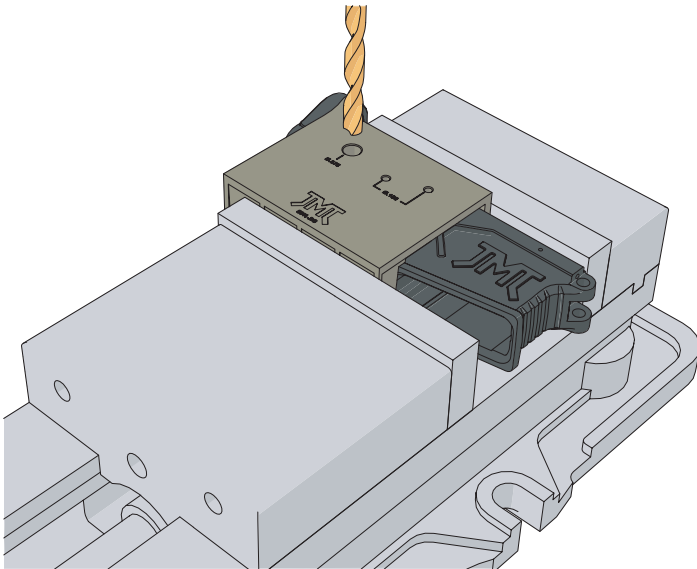

FIRMLY CLAMP THE ASSEMBLED LOWER RECEIVER AND JIG ASSEMBLY INTO YOUR VISE AS SHOWN AND SECURE TO THE TABLE OF YOUR MILL OR DRILL PRESS. VERIFY THAT THE SURFACE OF THE JIG IS LEVEL IN THE X AND Y AXIS.

USING THE 3/8" DIA. DRILL BIT, DRILL ALL OF THE WAY THROUGH THE LOWER RECEIVER IN THE LOCATION SHOWN. DRILL DOWN IN STEPS, FREQUENTLY RETRACTING THE BIT TO CLEAR CHIPS AND DEBRIS. THE HOLE DIAMETERS ARE MARKED ON THE JMT JIG RIGHT PLATE FOR REFERENCE.

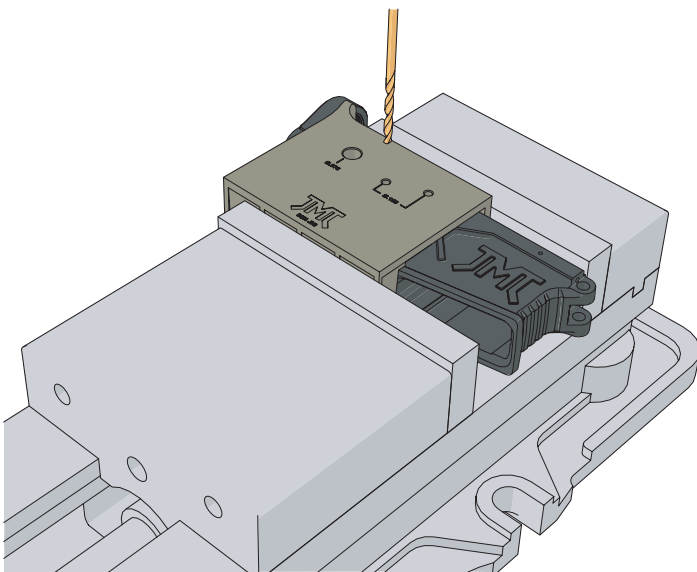

USING THE 5/32" DIA. DRILL BIT, DRILL ALL OF THE WAY THROUGH THE LOWER RECEIVER IN THE LOCATION SHOWN. DRILL DOWN IN STEPS, FREQUENTLY RETRACTING THE BIT TO CLEAR CHIPS AND DEBRIS.

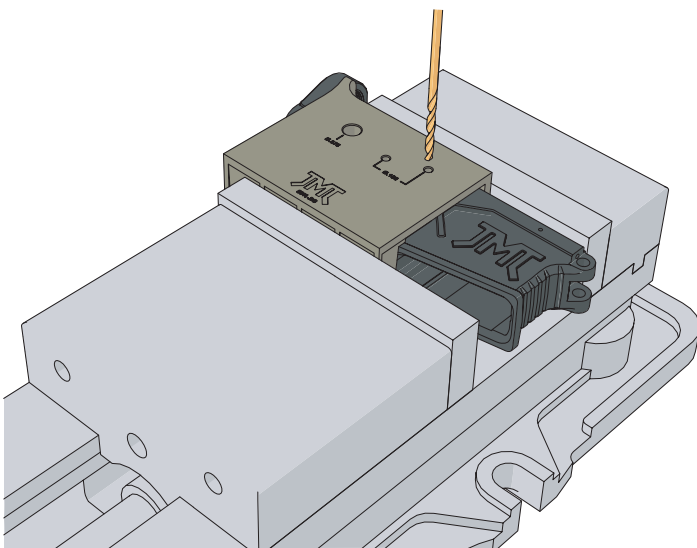

USING THE 5/32" DIA. DRILL BIT, DRILL ALL OF THE WAY THROUGH THE LOWER RECEIVER IN THE LOCATION SHOWN. DRILL DOWN IN STEPS, FREQUENTLY RETRACTING THE BIT TO CLEAR CHIPS AND DEBRIS.

RELEASE THE VISE AND REMOVE THE ASSEMBLED LOWER RECEIVER AND JIG. CLEAR ALL CHIPS AND DEBRIS FROM THE ASSEMBLY.

CUT ONE:

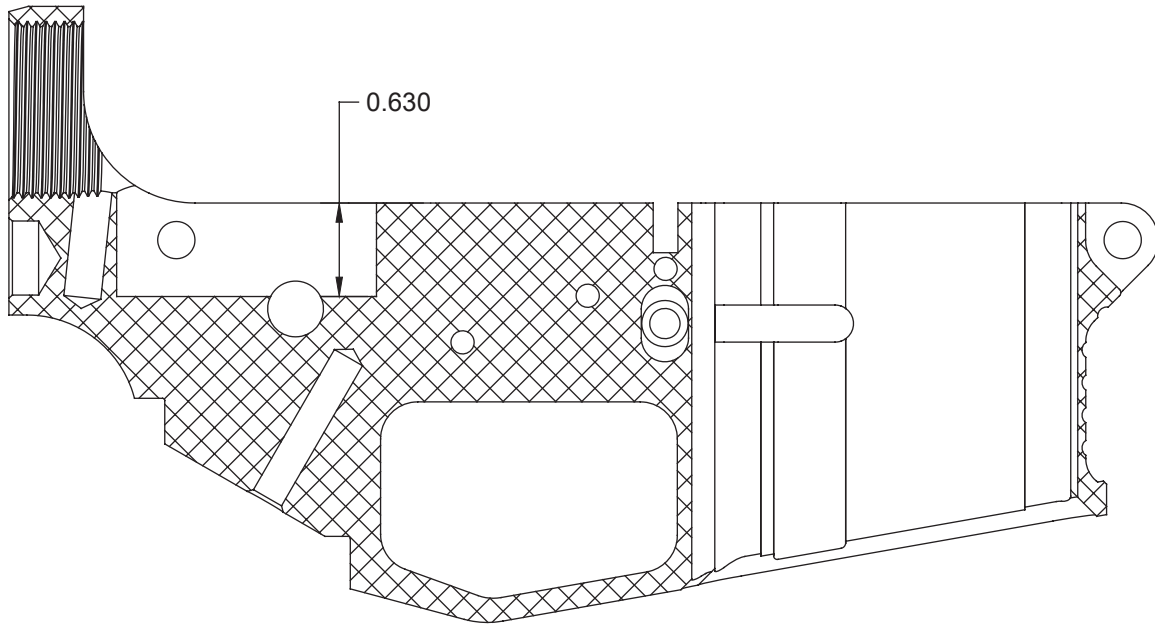
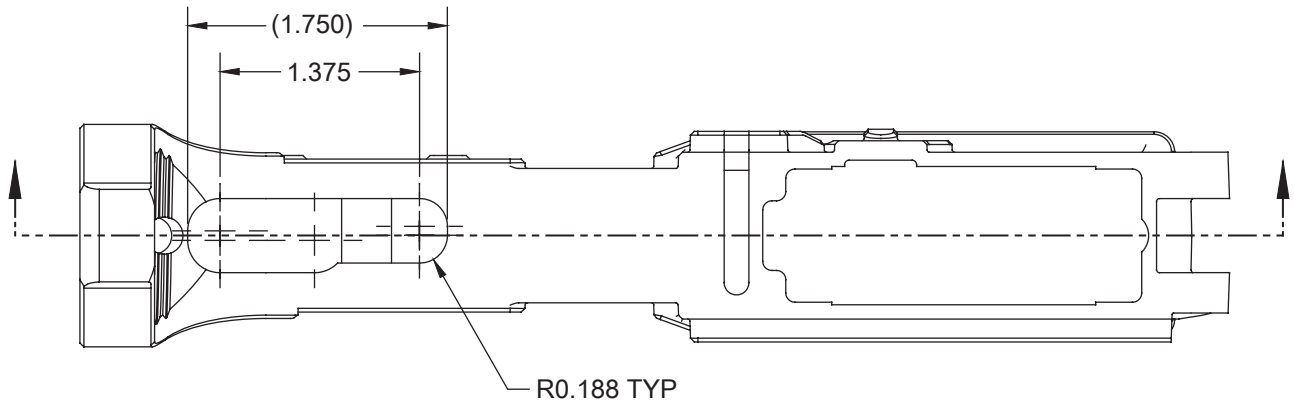

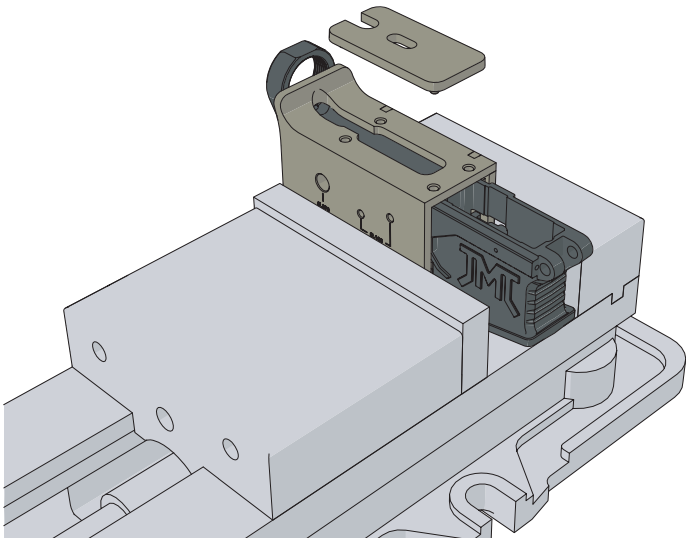

FIRMLY CLAMP THE ASSEMBLED LOWER RECEIVER AND JIG ASSEMBLY INTO YOUR VISE AS SHOWN.

NOTE: DEPENDING ON THE SIZE OF THE VISE JAWS YOU MAY NEED TO USE PLATES BETWEEN THE JAWS AND JIG TO ENSURE THE ASSEMBLY IS SECURELY CLAMPED. THIS WILL KEEP THE JIG FROM FLEXING DURING THE MACHINING OPERATION, ENSURING AN ACCURATE CUT.

VERIFY THAT THE SURFACE OF THE JIG IS LEVEL. INSTALL THE JIG TOP PLATE AS SHOWN WITH THE CUTOUT FACING THE REAR OF THE ASSEMBLY.

TAP THE JIG TOP PLATE IN TO PLACE UNTIL FULLY SEATED.

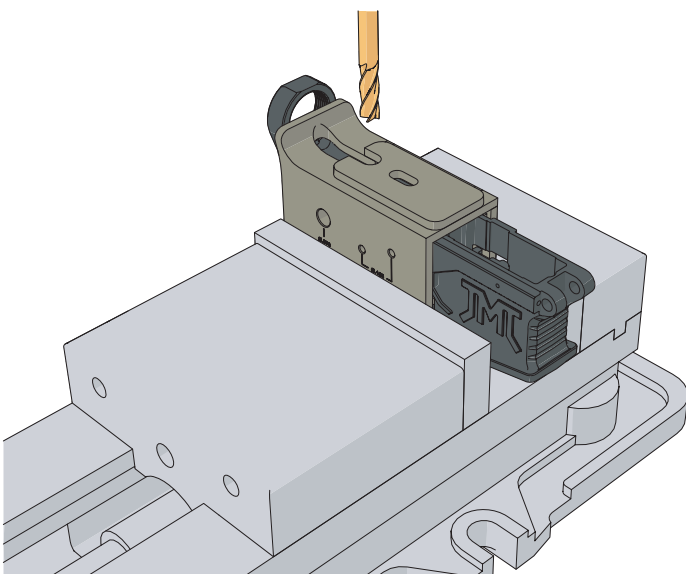

ZERO OUT ON THE TOP FACE OF THE LOWER RECEIVER, NOT THE JIG.

CUT IN STEPS, WE RECOMMEND CUTTING DOWN 1/8" (.125) AT A TIME. PAUSE FREQUENTLY TO CLEAR CHIPS AND DEBRIS.

USING THE 5/16" DIA. END MILL, FOLLOW THE PERIMETER OF THE CUTOUT IN THE JIG COMPLETELY,

USE CARE WHEN MACHINING NEAR THE BUFFER TUBE TOWER, CUTTING TOO FAR WILL BREAK IN TO THE BUFFER TUBE RETAINER PIN HOLE.

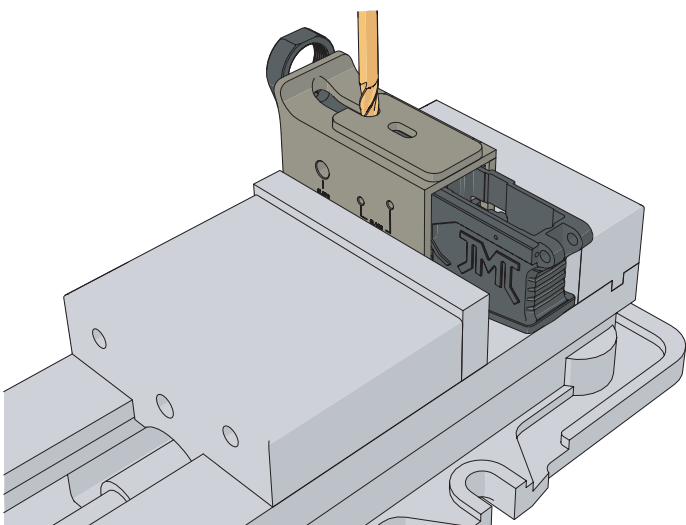

STEP DOWN AND REPEAT UNTIL YOU REACH THE 0.630" DEPTH NEEDED.

CLEAR ALL CHIPS AND DEBRIS FROM THE ASSEMBLY.

CUT TWO:

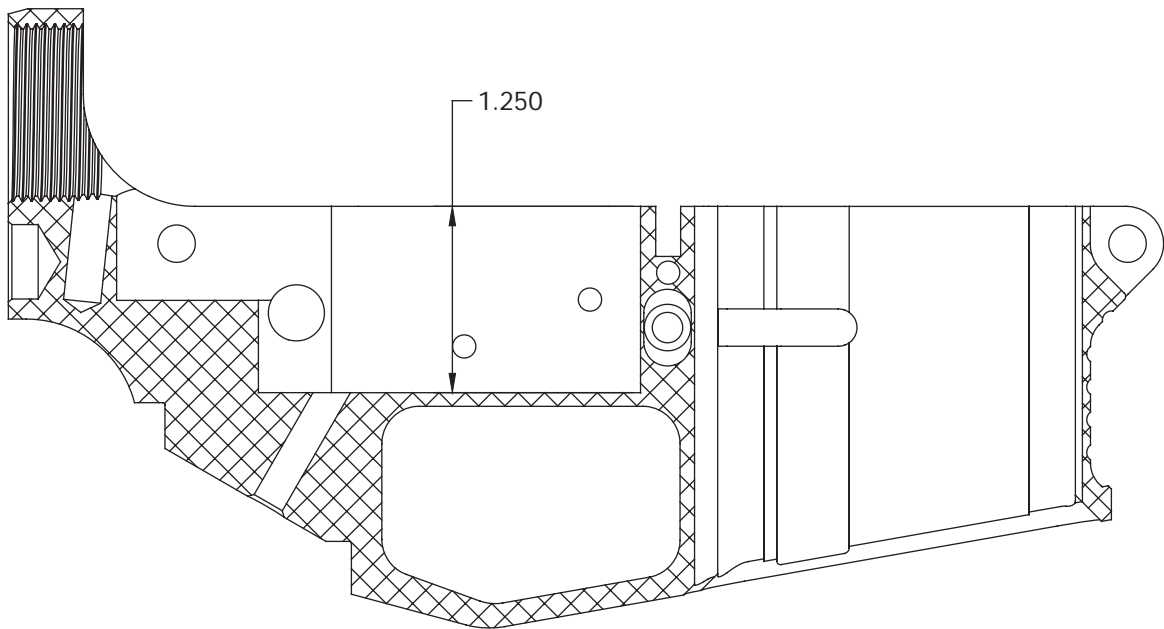
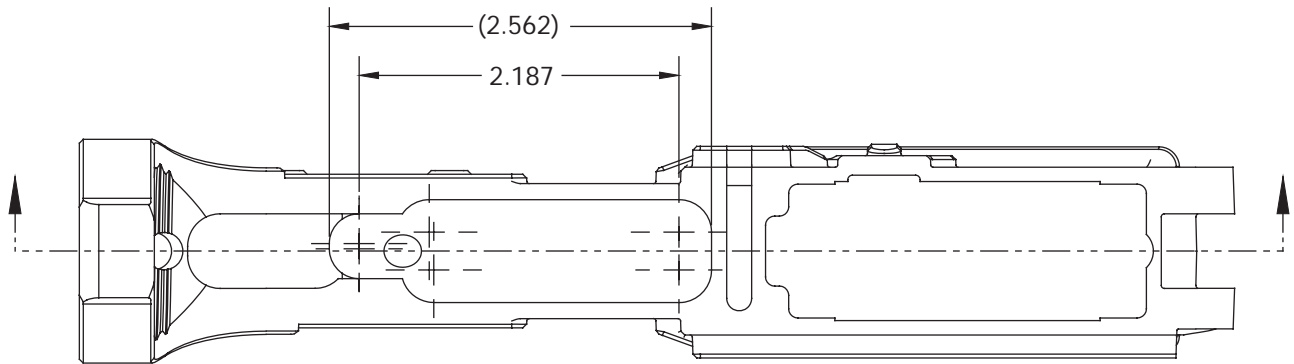

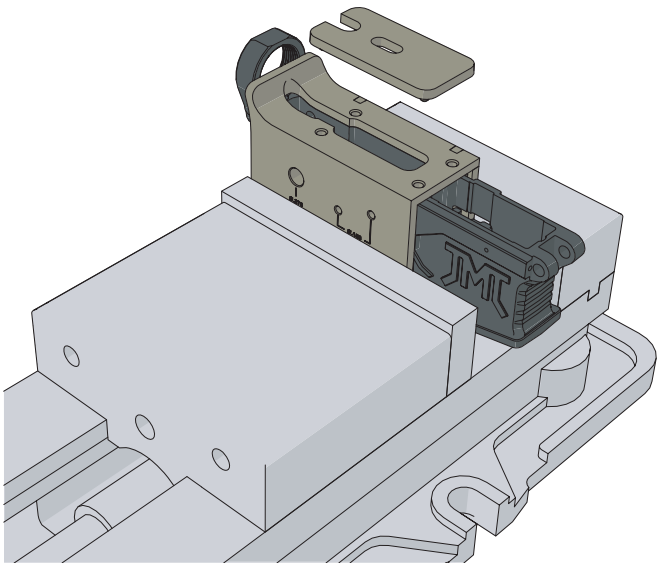

REMOVE THE JIG TOP PLATE FROM THE ASSEMBLY.

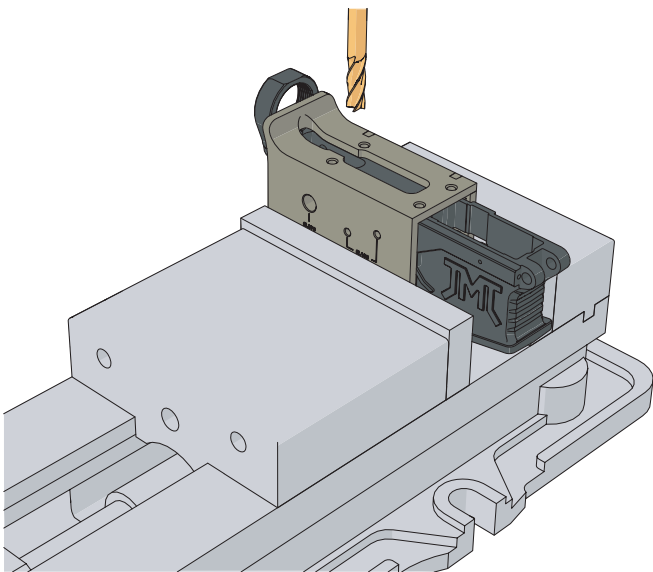

MACHINE THE POCKET SHOWN IN THE REFERENCE DRAWING USING THE 5/16" DIA. END MILL IN THE SAME MANOR AS BEFORE, STEPPING AS YOU GO.

BE MINDFUL OF THE LOCATION OF THE REAR OF THE POCKET, THIS IS THE MOST CRITICAL ASPECT OF THE MACHINING OPERATION, THERE IS NO GUIDE IN THE JIG TO PREVENT CUTTING TOO FAR.

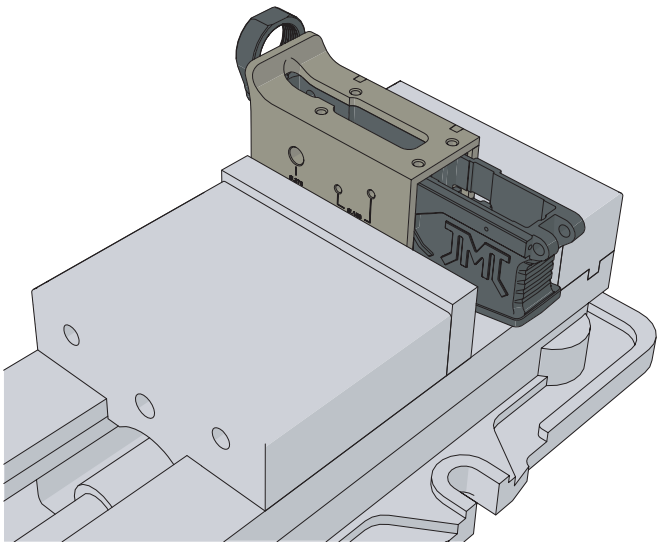

CLEAR ALL CHIPS AND DEBRIS FROM THE ASSEMBLY.

CUT THREE:

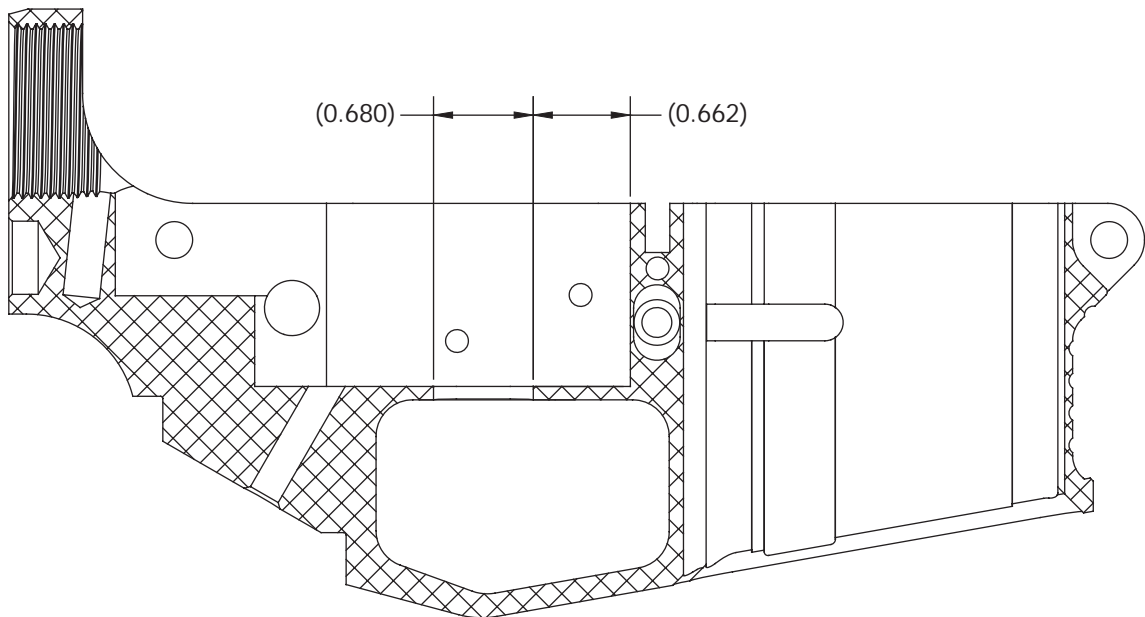
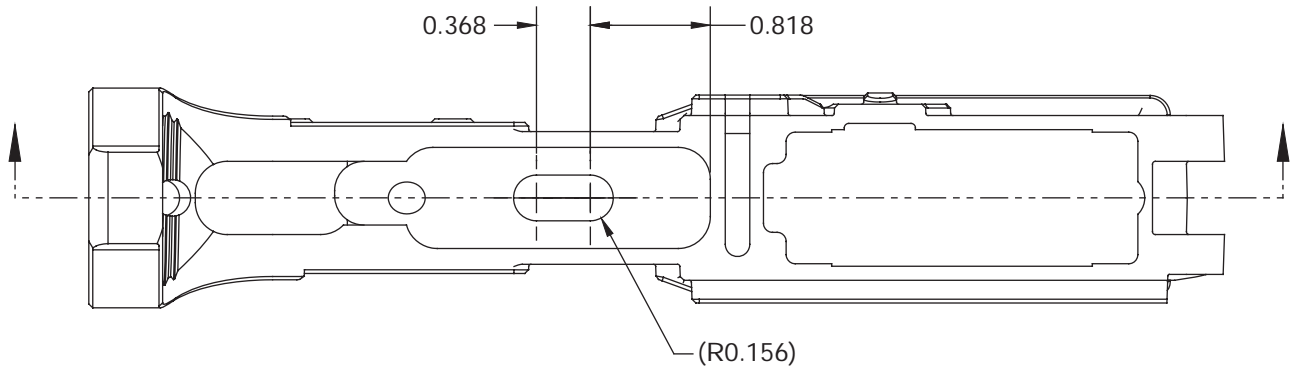

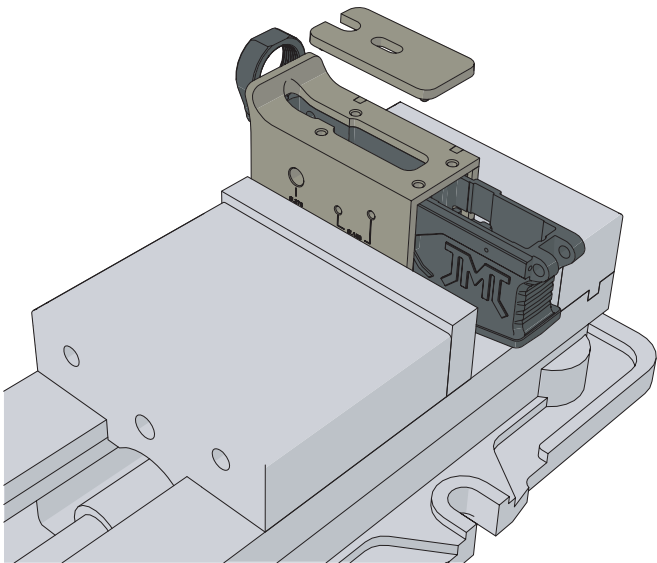

INSTALL THE JIG TOP PLATE AS SHOWN WITH THE CUTOUT FACING THE REAR OF THE ASSEMBLY.

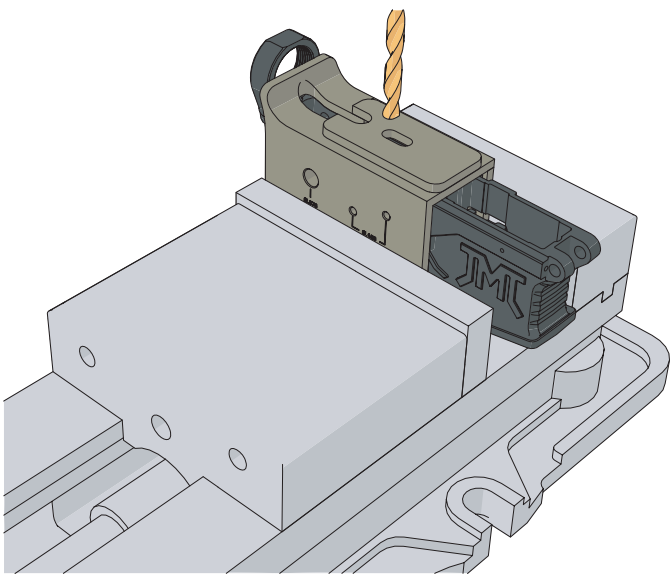

USING THE 5/16" DIA. (.313) DRILL BIT OR CUTTER MAKE THE CUT INDICATED IN THE REFERENCE DRAWING USING THE SLOT IN THE CENTER OF THE JIG TOP PLATE AS A GUIDE.

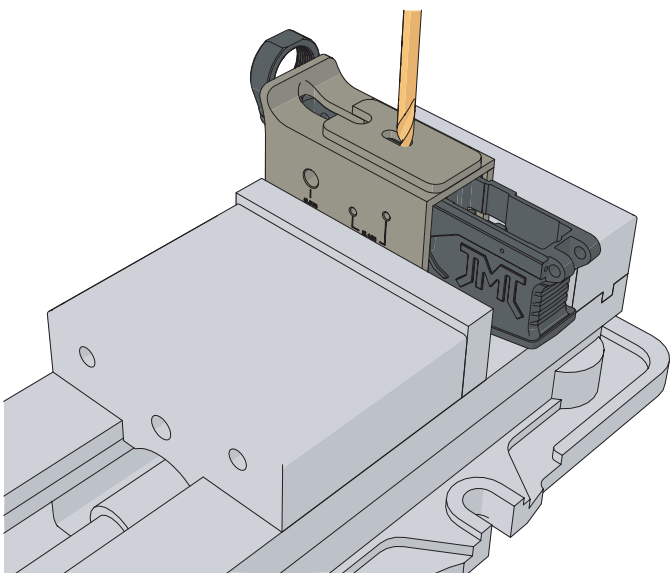

REMOVE THE ASSEMBLED LOWER RECEIVER AND JIG FROM THE VISE.

REMOVE THE JIG ASSEMBLY FROM THE LOWER RECEIVER AND CLEAR ALL CHIPS AND DEBRIS.

CLEAN UP ANY EDGES USING A SHARP BLADE.

CONGRATULATIONS, YOU HAVE COMPLETED THE MACHINING PROCESS, ENJOY YOUR JMT LOWER RECEIVER!